

SYLVANIA

Food Display lamps



SYLVANIA

foodstar



Food **display** lamps

Effective lighting design requires an understanding of the essential characteristics of the objects being illuminated – and how they respond to light. Never is this more relevant than in the lighting of food in supermarkets, butchers and bakeries, where the main objective is to make the produce appear appetising and appealing.

All light sources for food should have good colour rendering qualities, to bring out the colour nuances of different foodstuffs, but colour temperature can also have a crucial effect on appearance.

To be most attractive meat and charcuterie need a more reddish light accent but always displayed in balanced and harmonized colour. Most fruit and vegetables look good under medium-cool light sources. Fish looks best under quite cold lighting, while bread look its best when lit with warmer yellowish lamps



MEAT

Page 5-6

BREAD

Page 7-8

FRESH

Page 9-10



foodstar Food Lamps - Toughcoat™

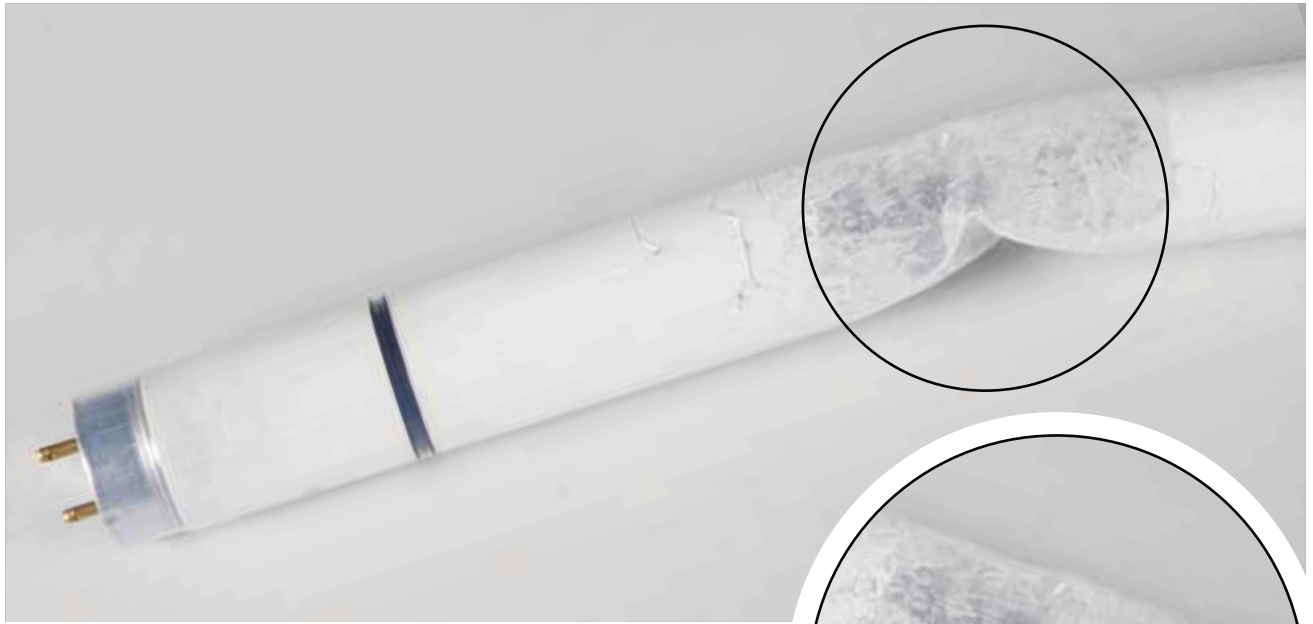

What are Toughcoat™ lamps?

Toughcoat™ lamps are shatter resistant lamps ensuring excellent fragment retention in the event of breakage. The tubes are coated with Teflon FEP (fluorinated ethylene propylene). FEP is a tough material which will not become brittle as it ages.

Why use Toughcoat™ lamps?

For many companies, especially those operating in the food area (also restaurants), the risk of glass and mercury contamination is real. Toughcoat lamps pay dividends in avoiding injury and contamination in case a lamp should be broken. Within the EU, Health and Safety regulations carry heavy penalties for avoidable injury of employees, making these lamps an especially sound investment, to meet the HACCP guidelines.

High quality features

- Excellent fragment retention in the event of breakage
- The protective FEP coating meets the IEC60068-2-75 Pendulum Hammer test (5 Joule) and the 4m drop test, demonstrating excellent glass retention in the event of accidental lamp breakage.
- No discolouration or yellowing of shatter resistant coating during the entire lamp life (> 10,000 hrs).
- The FEP material does not degrade during life. Versions employing PET coatings become brittle, and may not contain fragments.
- The coating withstands up to 200°C in both open and enclosed IP65 fittings. The melting temperature is 260°C.
- Meets all necessary regulations for resistance to heat and fire, and does not support combustion when exposed to naked flame or excessive heat. It passes the 850°C Glow Wire Test
- Satisfies the requirements of the International Food Standard (IFS 2004)
- FDA approved, in compliance with 21CFR177.1550 Regulatory Compliance Status.
- Satisfies the requirements of the BRC (British Retail Consortium) leading supermarkets global standard. In paragraph 3.2.2.6.2 it states "All bulbs and strip lights, including those on electric fly killer units, where they constitute a risk to products, shall be protected by shatterproof plastic diffusers, sleeve covers or with a shatterproof protective coating".



foodstar Meat - Fluorescent



G13



max 25,78

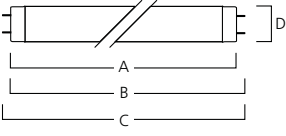

	A	B	B	C	D
T8	max	min	max	max	nom
18W	589.8	594.5	596.9	604.0	26
30W	894.6	899.3	901.7	908.8	26
36W	1199.4	1204.1	1206.5	1213.6	26
36W 1M	970.0	974.1	977.1	984.2	26
58W	1500.0	1504.7	1507.1	1514.2	26
70W	1763.8	1768.5	1770.9	1778.0	26

universal 



G5

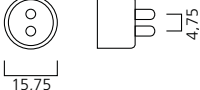

15,75

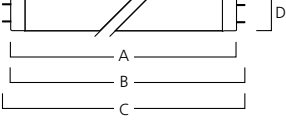

	A	B	B	C	D
T5	max	min	max	max	nom
14W	549	553.7	556.1	563.2	16
21W	849	853.7	856.1	863.2	16
28W	1149	1153.7	1156.1	1163.2	16
35W	1449	1453.7	1456.1	1463.2	16

universal 



- Features a specially tailored spectrum that complements the natural colours of meats.
- Illuminates meat and charcuterie in their optimum colours for an irresistible presentation.
- The truthful colour rendering does not disturb the natural colours of the products
- Manufactured in compliance with the DIN 10504 standard
- Available in Toughcoat-version (shatter proof). The protective FEP coating meets the IEC600682-75 pendulum hammer test (5 Joule) and 4m drop test demonstrating excellent glass retention in the event of accidental lamp breakage.

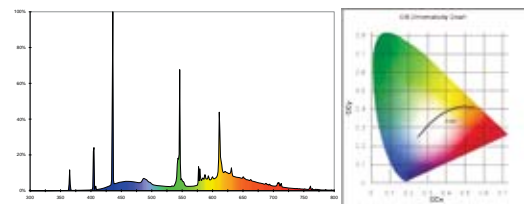

foodstar Meat - Fluorescent

Code	Description	Watt W	Volt V	Current A	Length mm	CRI	Cap	Colour Temp K	Luminous Flux lm	Packing Qty.
0001854	FHE 14W T5 176 FoodStar Meat	14	86	0.165	549	2A	G5	3000	650	25
0001819	FHE 21W T5 176 FoodStar Meat	21	126	0.165	849	2A	G5	3000	1050	25
0001820	FHE 28W T5 176 FoodStar Meat	28	166	0.170	1149	2A	G5	3000	1500	25
0001821	FHE 35W T5 176 FoodStar Meat	35	205	0.175	1449	2A	G5	3000	1850	25
0001855	F18W T8 176 FoodStar Meat	18	57	0.370	590	2A	G13	3000	700	25
0001856	F30W T8 176 FoodStar Meat	30	96	0.365	895	2A	G13	3000	1250	25
0001816	F36W T8 176 FoodStar Meat	36	103	0.430	1200	2A	G13	3000	1800	25
0001817	F36W T8 1M 176 FoodStar Meat	36	80	0.560	970	2A	G13	3000	1600	25
0001818	F58W T8 176 FoodStar Meat	58	110	0.670	1500	2A	G13	3000	2850	25
0001857	F70W T8 176 FoodStar Meat	70	128	0.700	1764	2A	G13	3000	3250	25

foodstar Meat - Fluorescent Toughcoat™

Code	Description	Watt W	Volt V	Current A	Length mm	CRI	Cap	Colour Temp K	Luminous Flux lm	Packing Qty.
0001787	FHE 14W T5 176 FoodStar Meat TC	14	86	0.165	549	2A	G5	3000	650	25
0001788	FHE 21W T5 176 FoodStar Meat TC	21	126	0.165	849	2A	G5	3000	1050	25
0001789	FHE 28W T5 176 FoodStar Meat TC	28	166	0.170	1149	2A	G5	3000	1500	25
0001790	FHE 35W T5 176 FoodStar Meat TC	35	205	0.175	1449	2A	G5	3000	1850	25
0001791	F18W T8 176 FoodStar Meat TC	18	57	0.370	590	2A	G13	3000	700	25
0001792	F30W T8 176 FoodStar Meat TC	30	96	0.365	895	2A	G13	3000	1250	25
0001793	F36W T8 176 FoodStar Meat TC	36	103	0.430	1200	2A	G13	3000	1800	25
0001794	F36W T8 1M 176 FoodStar Meat TC	36	80	0.560	970	2A	G13	3000	1600	25
0001795	F58W T8 176 FoodStar Meat TC	58	110	0.670	1500	2A	G13	3000	2850	25
0001796	F70W T8 176 FoodStar Meat TC	70	128	0.700	1764	2A	G13	3000	3250	25

foodstar Meat - RefLED

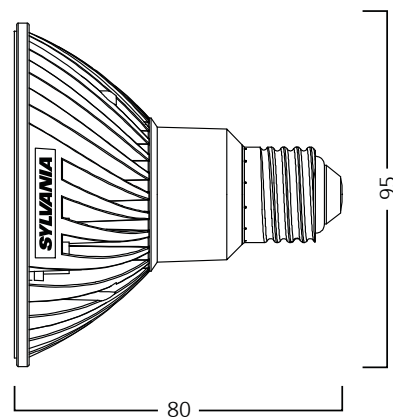
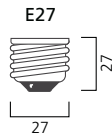

- Full retrofit LED for standard halogen lamps
- High energy saving: Compared to special colour halogen lamps
- Very long life: 25000hrs with more than 100000 switches.
- Features a specially tailored spectrum that complements the natural colours of meats
- Illuminates meat and charcuterie in their optimum colours for irresistible presentation
- The truthful colour rendering does not disturb the natural colours of the products
- Integrated electrical isolating transformer for highest safety, even in humid conditions

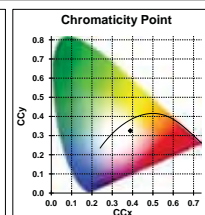
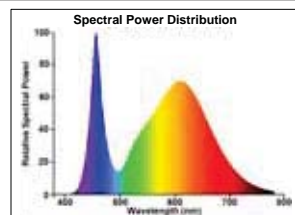

foodstar Meat - RefLED

Code	Description	Watt W	Volt V	Beam Angle	Cap	CRI	Colour Temp K	Luminous Flux lm	Average Rated Life	Packing Qty.
0001774	Hi-Spot 95 RefLED 9W 25° Foodstar Meat	9	220-240	25°	E27	80	3500	325	25000	10



foodstar Bread - Fluorescent



G13

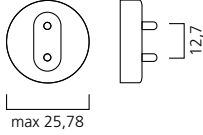

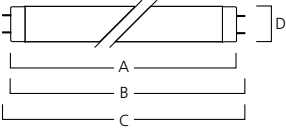

max 25,78





	A	B	B	C	D
T8	max	min	max	max	nom
18W	589.8	594.5	596.9	604.0	26
30W	894.6	899.3	901.7	908.8	26
36W	1199.4	1204.1	1206.5	1213.6	26
58W	1500.0	1504.7	1507.1	1514.2	26



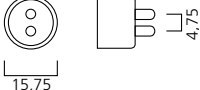

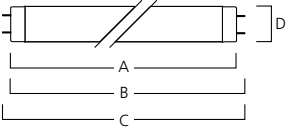

15,75



	A	B	B	C	D
T5	max	min	max	max	nom
21W	849	853.7	856.1	863.2	16
28W	1149	1153.7	1156.1	1163.2	16
35W	1449	1453.7	1456.1	1463.2	16

- FoodStar bread lamps have a radiation concentrated in the yellowish part of the spectrum
- Truthful colour rendering does not disturb the natural colours of the products
- Reduced warm up of the goods illuminated
- Available in Toughcoat-version (shatter proof). The protective FEP coating meets the IEC600682-75 pendulum hammer test (5 Joule) and 4m drop test demonstrating excellent glass retention in the event of accidental lamp breakage.

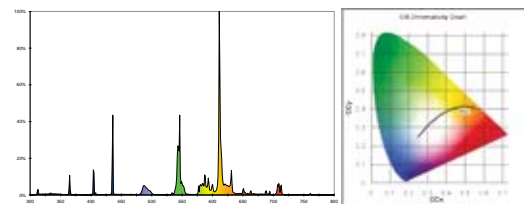

foodstar Bread - Fluorescent

Code	Description	Watt W	Volt V	Current A	Length mm	CRI	Cap	Colour Temp K	Luminous Flux lm	Packing Qty.
0001858	FHE 21W T5 FoodStar Bread	21	126	0.165	849	2A	G5	2300	1650	25
0001859	FHE 28W T5 FoodStar Bread	28	166	0.170	1149	2A	G5	2300	2250	25
0001860	FHE 35W T5 FoodStar Bread	35	205	0.175	1449	2A	G5	2300	2850	25
0001861	F18W T8 FoodStar Bread	18	57	0.370	590	2A	G13	2300	1100	25
0001862	F30W T8 FoodStar Bread	30	96	0.365	895	2A	G13	2300	2100	25
0001863	F36W T8 FoodStar Bread	36	103	0.430	1200	2A	G13	2300	3000	25
0001864	F58W T8 FoodStar Bread	58	110	0.670	1500	2A	G13	2300	4500	25

foodstar Bread - Fluorescent Toughcoat™

Code	Description	Watt W	Volt V	Current A	Length mm	CRI	Cap	Colour Temp K	Luminous Flux lm	Packing Qty.
0001797	FHE 21W T5 FoodStar Bread TC	21	126	0.165	849	2A	G5	2300	1650	25
0001798	FHE 28W T5 FoodStar Bread TC	28	166	0.170	1149	2A	G5	2300	2250	25
0001799	FHE 35W T5 FoodStar Bread TC	35	205	0.175	1449	2A	G5	2300	2850	25
0001800	F18W T8 FoodStar Bread TC	18	57	0.370	590	2A	G13	2300	1100	25
0001801	F30W T8 FoodStar Bread TC	30	96	0.365	895	2A	G13	2300	2100	25
0001802	F36W T8 FoodStar Bread TC	36	103	0.430	1200	2A	G13	2300	3000	25
0001803	F58W T8 FoodStar Bread TC	58	110	0.670	1500	2A	G13	2300	4500	25

foodstar Bread - RefLED

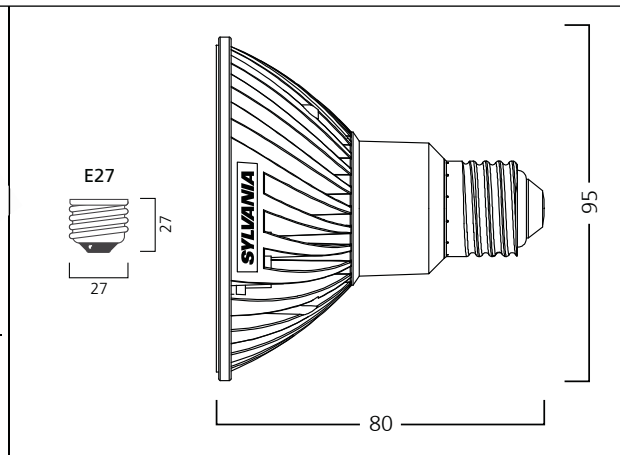

- Full retrofit LED for standard halogen lamps
- High energy saving: Compared to white sodium and filtered metal halide lamps
- Very long life: 25000hrs with more than 100000 switches.
- Features a specially tailored spectrum that complements the natural colours of bread and patisserie. Illuminates them in their optimum colours for irresistible presentation
- The truthful colour rendering does not disturb the natural colours of the products
- Integrated electrical isolating transformer for highest safety, even in humid conditions

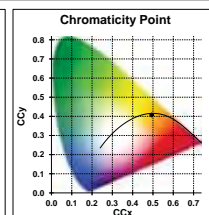
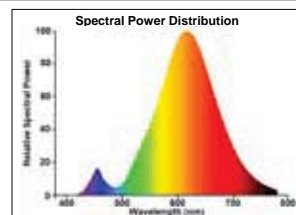

foodstar Bread - RefLED

Code	Description	Watt W	Volt V	Beam Angle	Cap	CRI	Colour Temp K	Luminous Flux lm	Average Rated Life	Packing Qty.
0001777	Hi-Spot 95 RefLED 9W 25° Foodstar Bread	9	220-240	25°	E27	80	2200	300	25000	10



foodstar Fresh - Fluorescent



G13

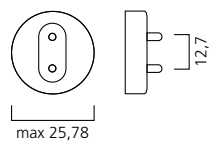

max 25,78

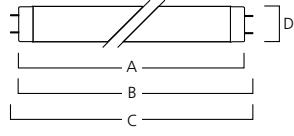

A

B

C

D

	A	B	B	C	D
T8	max	min	max	max	nom
36W	1199.4	1204.1	1206.5	1213.6	26
58W	1500.0	1504.7	1507.1	1514.2	26



universal





G5

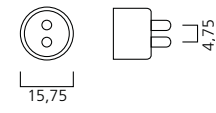

15,75

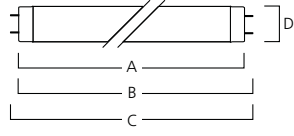

A

B

C

D

	A	B	B	C	D
T5	max	min	max	max	nom
21W	849	853.7	856.1	863.2	16
28W	1149	1153.7	1156.1	1163.2	16
35W	1449	1453.7	1456.1	1463.2	16



universal





- Fruit and vegetables should reflect freshness. They need a higher colour temperature and cooler light and the display of fish needs it even more.
- Truthful colour rendering does not disturb the natural colours of the products
- Reduced warm up of the goods illuminated
- Available in Toughcoat-version (shatter proof). The protective FEP coating meets the IEC600682-75 pendulum hammer test (5 Joule) and 4m drop test demonstrating excellent glass retention in the event of accidental lamp breakage.

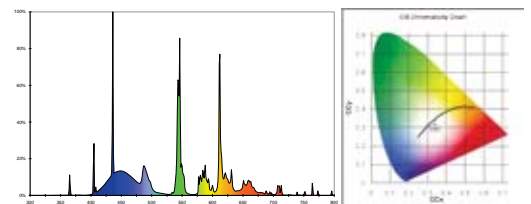

foodstar Fresh - Fluorescent

Code	Description	Watt W	Volt V	Current A	Length mm	CRI	Cap	Colour Temp K	Luminous Flux lm	Packing Qty.
0001865	FHE 21W T5 FoodStar Fresh	21	126	0.165	849	2A	G5	6400	1250	25
0001866	FHE 28W T5 FoodStar Fresh	28	166	0.170	1149	2A	G5	6400	1700	25
0001867	FHE 35W T5 FoodStar Fresh	35	205	0.175	1449	2A	G5	6400	2150	25
0001868	F36W T8 FoodStar Fresh	36	103	0.430	1200	2A	G13	6400	2350	25
0001869	F58W T8 FoodStar Fresh	58	110	0.670	1500	2A	G13	6400	3500	25

foodstar Fresh - Fluorescent Toughcoat™

Code	Description	Watt W	Volt V	Current A	Length mm	CRI	Cap	Colour Temp K	Luminous Flux lm	Packing Qty.
0001804	FHE 21W T5 FoodStar Fresh TC	21	126	0.165	849	2A	G5	6400	1250	25
0001805	FHE 28W T5 FoodStar Fresh TC	28	166	0.170	1149	2A	G5	6400	1700	25
0001806	FHE 35W T5 FoodStar Fresh TC	35	205	0.175	1449	2A	G5	6400	2150	25
0001807	F36W T8 FoodStar Fresh TC	36	103	0.430	1200	2A	G13	6400	2350	25
0001808	F58W T8 FoodStar Fresh TC	58	110	0.670	1500	2A	G13	6400	3500	25

foodstar Fresh - RefLED

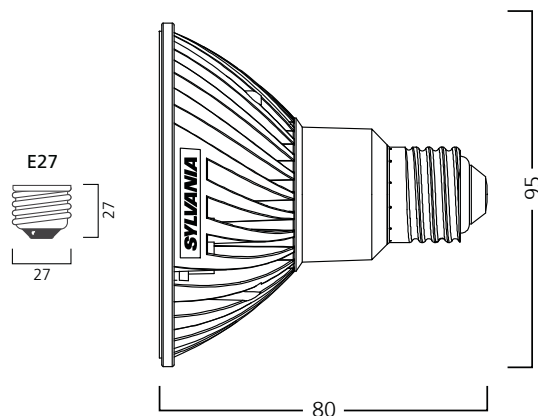

- Full retrofit LED for standard halogen lamps
- High energy saving
- Very long life: 25000hrs with more than 100000 switches.
- Features a specially tailored spectrum that complements the natural colours of fruit, vegetables and fish. Illuminates them in their optimum colours for irresistible presentation
- The truthful colour rendering does not disturb the natural colours of the products
- Integrated electrical isolating transformer for highest safety, even in humid conditions

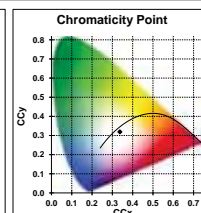
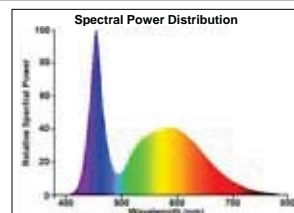

foodstar Fresh - RefLED

Code	Description	Watt W	Volt V	Beam Angle	Cap	CRI	Colour Temp K	Luminous Flux lm	Average Rated Life	Packing Qty.
0001780	Hi-Spot 95 RefLED 9W 25° Foodstar Fresh	9	220-240	25°	E27	80	5000	375	25000	10



EUROPE

Austria

Vienna
T. +43 (0)1617 4480
F. +43 (0)1617 4481
info.at@havells-sylvania.com

Belgium

Antwerp
T. +32 (0)3 610 44 44
F. +32 (0)3 610 44 57
info.be@havells-sylvania.com

Czech Republic, Slovakia, Slovenia, Croatia, Bosnia and Herzegovina

T. +420 545 231 345
F. +420 545 231 346
info.cz@havells-sylvania.com

Finland

Helsinki
T. +358 (0)9 5421 2100
F. +358 (0)9 5421 2130
info.fi@havells-sylvania.com

France

Paris
T. +33 (0)1 55 51 11 00
F. +33 (0)1 55 51 11 15
info.fr@havells-sylvania.com

Germany

Erlangen
T. +49 (0)9131 793 0
F. +49 (0)9131 793 345
info.de@havells-sylvania.com

Greece

Athens
T. +30 210 996 65 61
F. +30 210 996 90 29
info.gr@havells-sylvania.com

Hungary, Serbia, Montenegro, Romania

Budapest
T. +36 (30) 50 69 182
F. +36 (24) 423 563
info.hu@havells-sylvania.com

Italy

Milan
T. +39 02 24 12 58 11
F. +39 02 24 12 58 80
info.it@havells-sylvania.com

Netherlands

Breda
T. +31 (0)76 750 44 44
F. +31 (0)76 750 44 56
info.nl@havells-sylvania.com

Norway

Oslo
T. +47 23 067470
F. +47 23 067471
info.no@havells-sylvania.com

Poland

Warsaw
T. +48 22 811 60 32
F. +48 22 811 60 33
info.pl@havells-sylvania.com

Portugal

Lisbon
T. +351 21 793 77 36/37
F. +351 21 793 77 38
info.pt@havells-sylvania.com

Russia

Moscow
T. +7 495 935 70 48
F. +7 495 937 70 08
info.ru@havells-sylvania.com

Spain

Madrid
T. +34 91 669 90 00
F. +34 91 673 73 64
info.es@havells-sylvania.com

Sweden

Stockholm
T. +46 8 556 322 00
F. +46 8 556 322 10
info.se@havells-sylvania.com

Switzerland

Zurich
T. +41 44305 31 80
F. +41 44305 31 81
info.ch@havells-sylvania.com

Turkey

Istanbul
Albania, Asian CIS (Azerbaijan,
Georgia, Kyrgyzstan, Tajikistan,
Turkmenistan, Uzbekistan),
Bulgaria, N. Cyprus,
Macedonia
T. +90 212 343 46 10
F. +90 212 343 46 10
info.tr@havells-sylvania.com

UK

Newhaven
T. +44 870 606 2030
F. +44 1273 512 688
info.uk@havells-sylvania.com
info.concord@havells-sylvania.com

Ukraine

Kyiv
T. +380 44 3861091

MIDDLE EAST

United Arab Emirates

Dubai
T. +971 4 2998141
F. +971 4 2998142
info.ae@havells-sylvania.com

ASIA

China

Guangzhou
T. +86 20 3815 1138
F. +86 20 3869 7572
info.cn@havells-sylvania.com

India

Noida
T. +91 120 477 1000
F. +91 120 477 2000
marketing@havells.com

Malaysia

Kuala Lumpur
T. +603 2031 8788
F. +603 2031 4788

Thailand

Bangkok
T. +66 2656 9039
F. +66 2254 3369
info.th@havells-sylvania.com

Vietnam

Hanoi
T. +844 37 151 604
F. +844 37 151 605
info.vn@havells-sylvania.com

AMERICAS

Argentina

Buenos Aires
T. +54 11 4515 0215
F. +54 11 4515 0215
info.ar@havells-sylvania.com

Brazil

São Paulo
T. +55 11 3133 2400
F. +55 11 5521 3660
info.br@havells-sylvania.com

Caribbean

Honduras, Nicaragua
San José
T. +506 22 107 678
F. +506 22 328 723
info.cr@havells-sylvania.com

Chile

Santiago

Colombia

Santafé de Bogota
T. +57 1 782 5200
F. +57 1 719 9621
info.co@havells-sylvania.com

Costa Rica

San José
T. +506 22 107 678
F. +506 22 200 338
sales@havells-sylvania.com

Ecuador

Quito
T. +593 2 328 4407
F. +593 2 281 0007
info.ec@havells-sylvania.com

El Salvador

San Salvador
T. +503 2239 2239
F. +503 2284 9670
info.sv@havells-sylvania.com

Guatemala

Guatemala City
T. +502 2387 5300
F. +502 2387 5301
info.gt@havells-sylvania.com

Mexico

Mexico D.F.
T. +52 55 5387 7670
F. +52 55 5387 7671
info.mx@havells-sli.com

Panama

Panama City
T. +507 236 1000
F. +507 236 1315
info.pa@havells-sylvania.com

Peru

Lima
T. +511 446 1435/ 446 9939
F. +511 446 9990

USA

Atlanta, G.A.
T. 1 800 922 6693
info.us@havells-USA.com

Venezuela

Caracas
T. +58 212 381 0452
F. +58 212 381 0350
info.ve@havells-sylvania.com

www.havells-sylvania.com

SYLVANIA